



LBS-1600 / Load Bank



Features

- UL/CUL Listed
- Slide-out, tray mounted load elements
- Branch circuit fuse protection of load elements
- Digital Control
- Comprehensive malfunction detection system
- Modular enclosure design with separate and isolated control and power sections
- Type 3R, oversize control section with generous cable connection space
- Vertical airflow, exhausts hot air above level of personnel and away from buildings, pavement etc.
- Comprehensive overload, short circuit and malfunction protection

Specifications

High capacity: 2,146 hp (1,600 kW)
Voltage: All common 3-phase 50/60 Hz voltages
Digital load control, 5 kW load step resolution
Touchscreen operator interface

The Taylor Dynamometer LBS-1600 is stationary, outdoor (or indoor) load bank designed to provide high capacity load testing of generators, UPS, and other AC power sources; periodic reliability exercise of standby generators and other load bank applications. Operator interface is via a handheld remote controller with touchscreen. Load control is via screen keypad. All electrical values are displayed on the screen and recorded by the system for future data retrieval.

The LBS-1600 offers resistive load for all common 3-phase 60, 50 Hz voltages:

60 Hz: 208 V, 220 V, 240 V, 416 V, 440 V, 450 V, 460 V, 480 V, 575 V and 600 V

50 Hz: 190 V, 200 V, 208 V, 380 V, 400 V and 416 V

Total Test Success

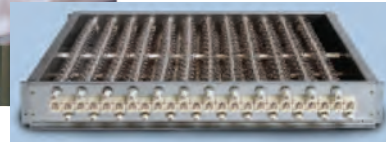

Resistive Load Element

The LBS load bank uses an advanced design, air-cooled power resistor specifically designed for application to Load Bank systems. The elements are conservatively operated at half the maximum temperature rating of the alloy and features a short-circuit safe design based on continuous mechanical support of the element by high temperature, ceramic clad stainless steel rods. The elements are assembled into discrete trays which are assembled in a vertical "stack." Each tray in the "stack" is independently serviceable without disturbing adjacent trays.

Specifications

Alloy: FeCrAl

Maximum continuous temperature rating: 1,920°F (1,049°C)

Maximum operating temperature as applied in Load Bank: 1,080°F (582°C)

Cool down time from operating to ambient temperature is 10 seconds

Construction

- Ceramic clad, stainless steel through rods
- UL Recognized

Capacity

Model	240/480 V	400 V	380 V 3-phase 50/60 Hz
LBS-1600	1,600 kW	1,111 kW	1,002 kW

Cooling System

Model	hp (kW)	CFM (M ³ /H)	Exhaust Rise °F (°C)	Hot Spots °F (°C)
LBS-1600	30 (22.3)	60,000 (101,940)	150-200 (65-93)	575 (301)

Digital Load Step Control

5.0 kW step resolution

Detailed Specifications

Voltage

All common 3-phase 60, 50 Hz voltages:

60 Hz: 208 V, 220 V, 240 V, 416 V, 440 V, 450 V, 460 V, 480 V, 575 V and 600 V

50 Hz: 190 V, 200 V, 208 V, 380 V, 400 V and 416 V

Frequency

50, 60 Hz

Connection

Plated bus bar within an oversized terminal junction box

Time Rating

Continuous

Ambient Air Temperature

120°F (49°C) maximum

Control/Fan Power

External or internal from load bus. Control circuits at 120 V via transformer. The cooling fan operates at 3-phase line voltage. Load control circuits and fan motor control operate at 120 V. Control circuits are fused. Control circuit fuses are 100,000 A.I.C., 600 V rated.

Net Weight

Load Bank is 5,200 lb (2,358 kg)
Exhaust Hood is 940 lb (426 kg)

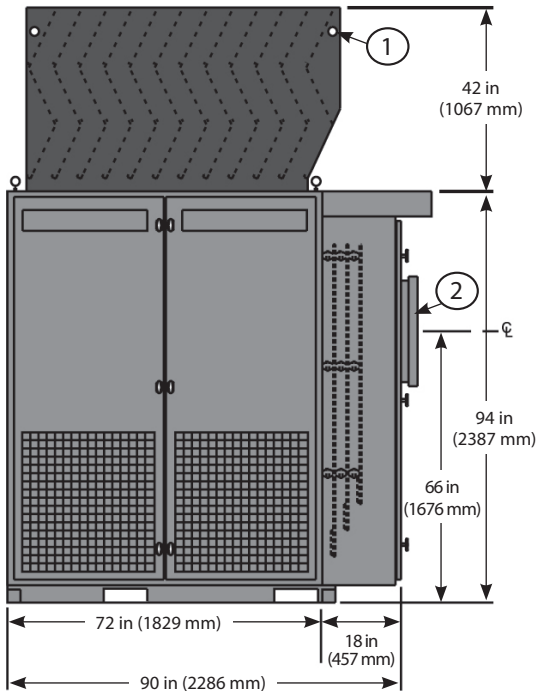

Left Side View

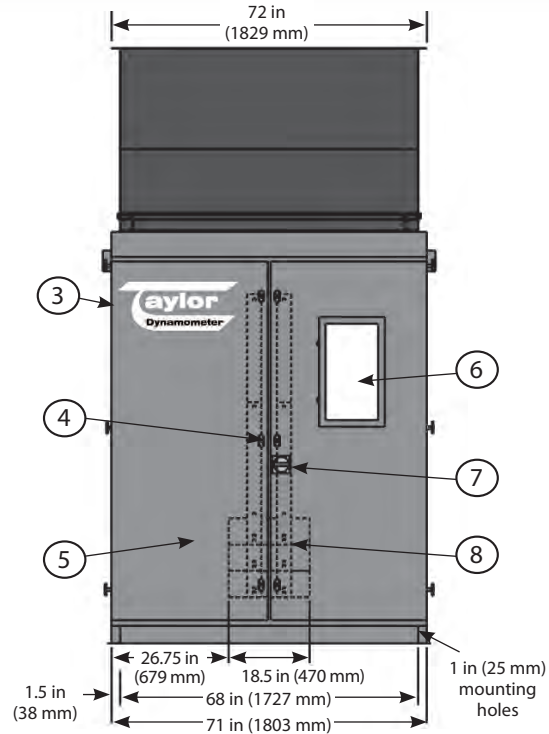

Front View

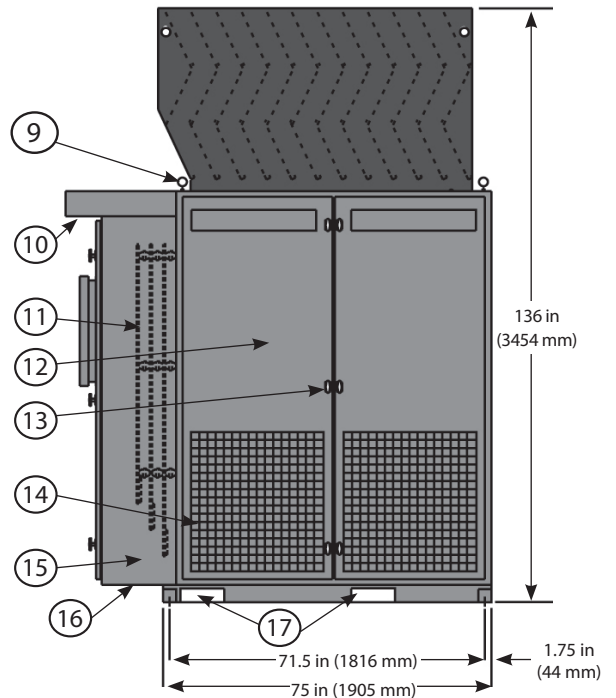

Right Side View

Features

1. Lifting provisions (for exhaust hood only)
2. Control panel
3. Stainless steel hinge
4. Lockable latch
5. Control compartment hinged door
6. Local control panel hinged door
7. Optional disconnect switch
8. Load source connections
9. Lift eyes (4) removable
10. Rain shield vent screen
11. Distribution bus tin/silver plated copper bar
12. Hinged doors access to load elements
13. Lockable latch
14. Screened air intake (2 each side)
15. Nema 3R control section
16. Conduit entry location
17. Forklift channels

Everything you need to succeed

