

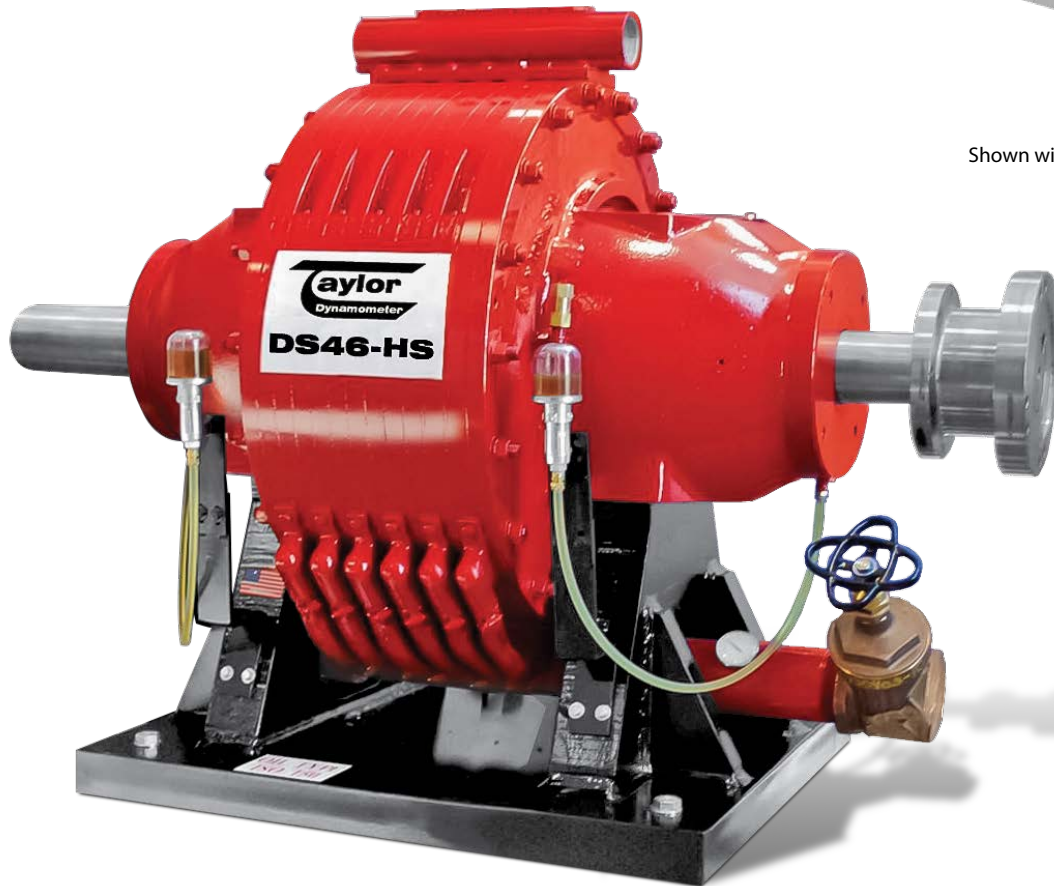

DS46-HS / Engine Dynamometer



Shown with optional flange.

DS46-HS Water Brake Engine Dynamometer

Specifications

Power:	2,125 hp (1,584 kW)
Torque:	7,125 lb-ft (9,660 Nm)
Speed:	4,000 rpm
Water Use*:	147 gpm (556.5 lpm)
Inertia Value**:	172.4 lb·ft ² (7.3 kg·m ²)
Shipping Weight:	2,860 lb (1,297 kg)
Rotation:	bi-directional

*No Cooling System

** With Companion Flange or Torsional Coupling

Recommended Accessories

- Driveshaft
- Torsional Coupling
- Adapter Plate Kit
- Shaft Guard
- Sub-Base Kit
- Engine Cart
- Air Starter - High Torque, Single or Dual Directional
- Cooling Column - 4,250 hp (3,169 kW)
- Charge Air Cooler
- Water Recirculating System

For overhung loads, such as a belt or gear drive, please contact Taylor Dynamometer to ensure that the system will meet the required performance needs.

Total Test Success

Optional Accessories

Optional dual directional
pneumatic starter kit
with flywheel and flywheel guard

Optional shaft
guard

DS4012 shown
with available options

Optional
Sub-Base

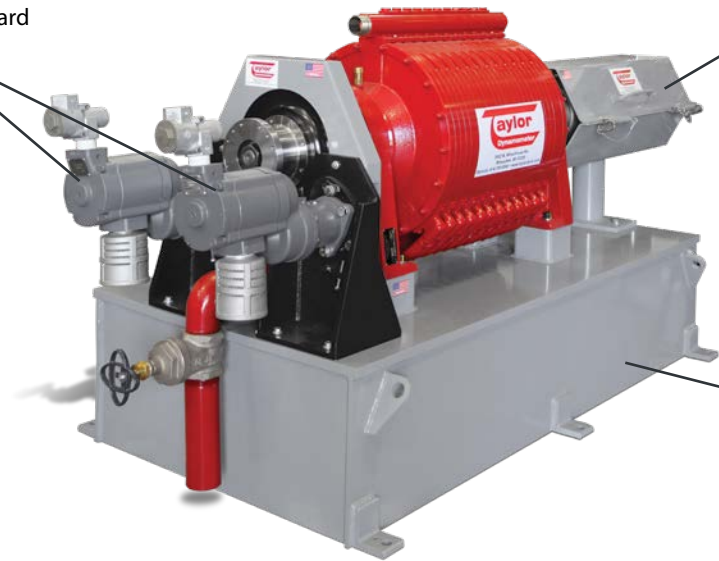

Optional
Cooling Column



Optional
Engine Cart



Optional Charge
Air Cooler

Various Facility Support Systems and Services Available



Bulk Fuel Storage
and Distribution



Coolant Storage
and Distribution



Water
Recirculation



Design, Project
& Construction
Management Services



Commissioning,
Start-up & Training

DS46-HS (US Customary)

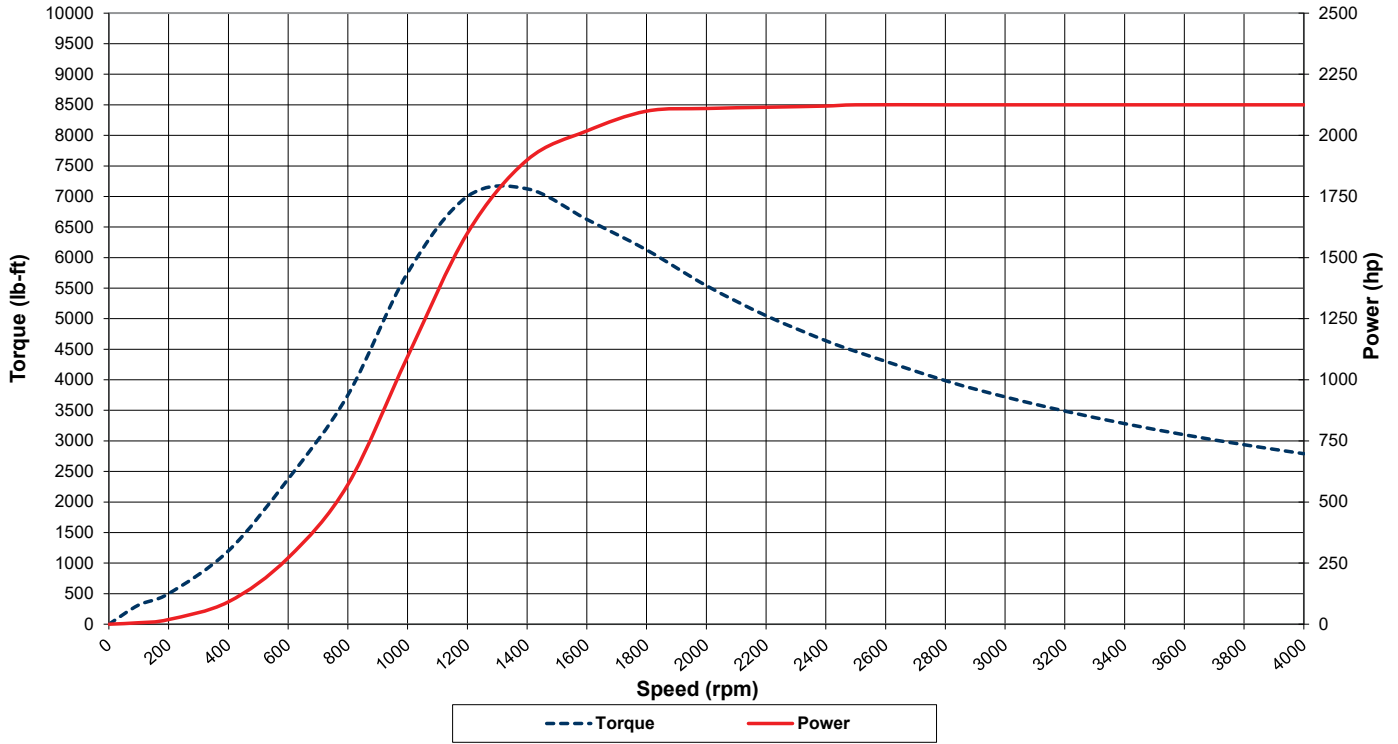

DS46-HS (S.I.)

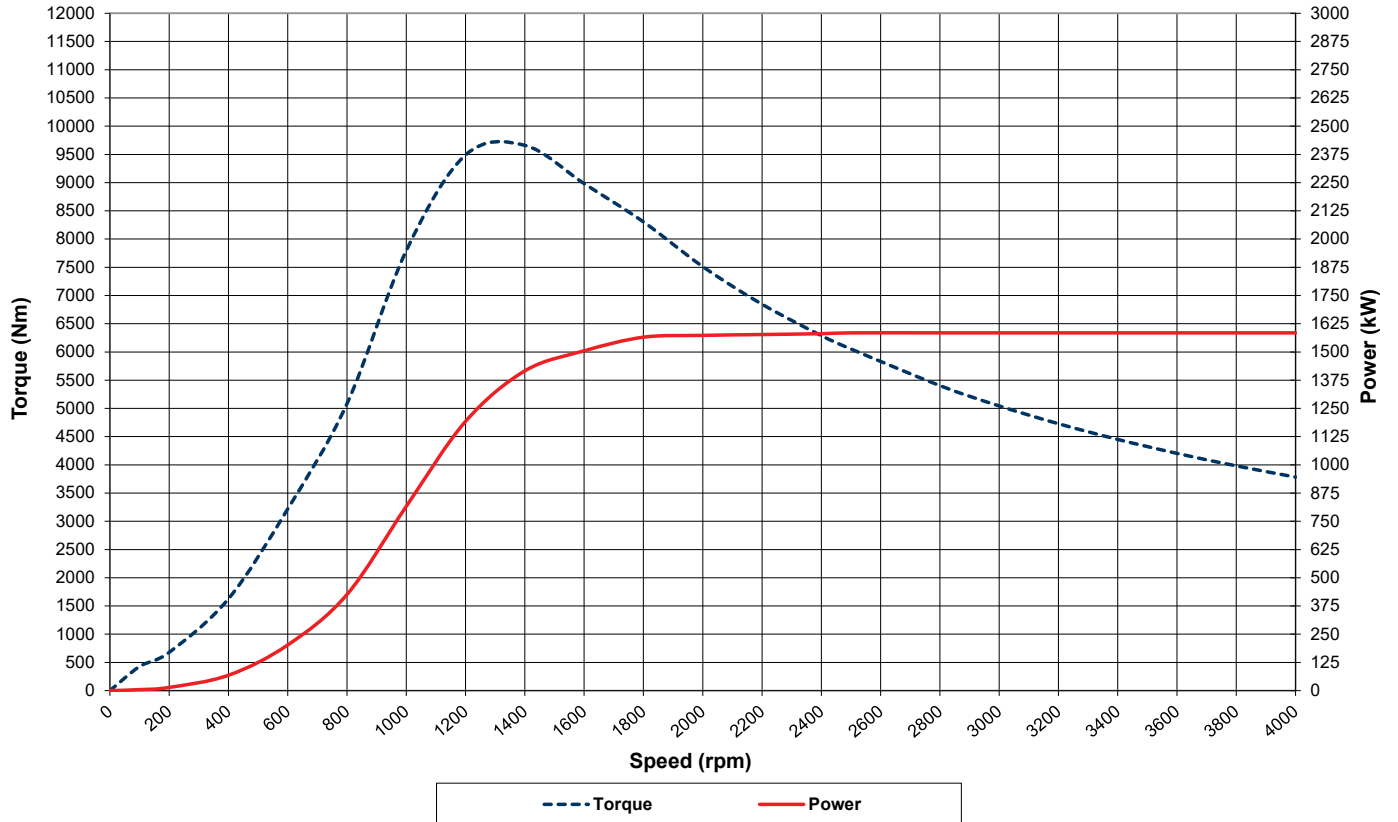

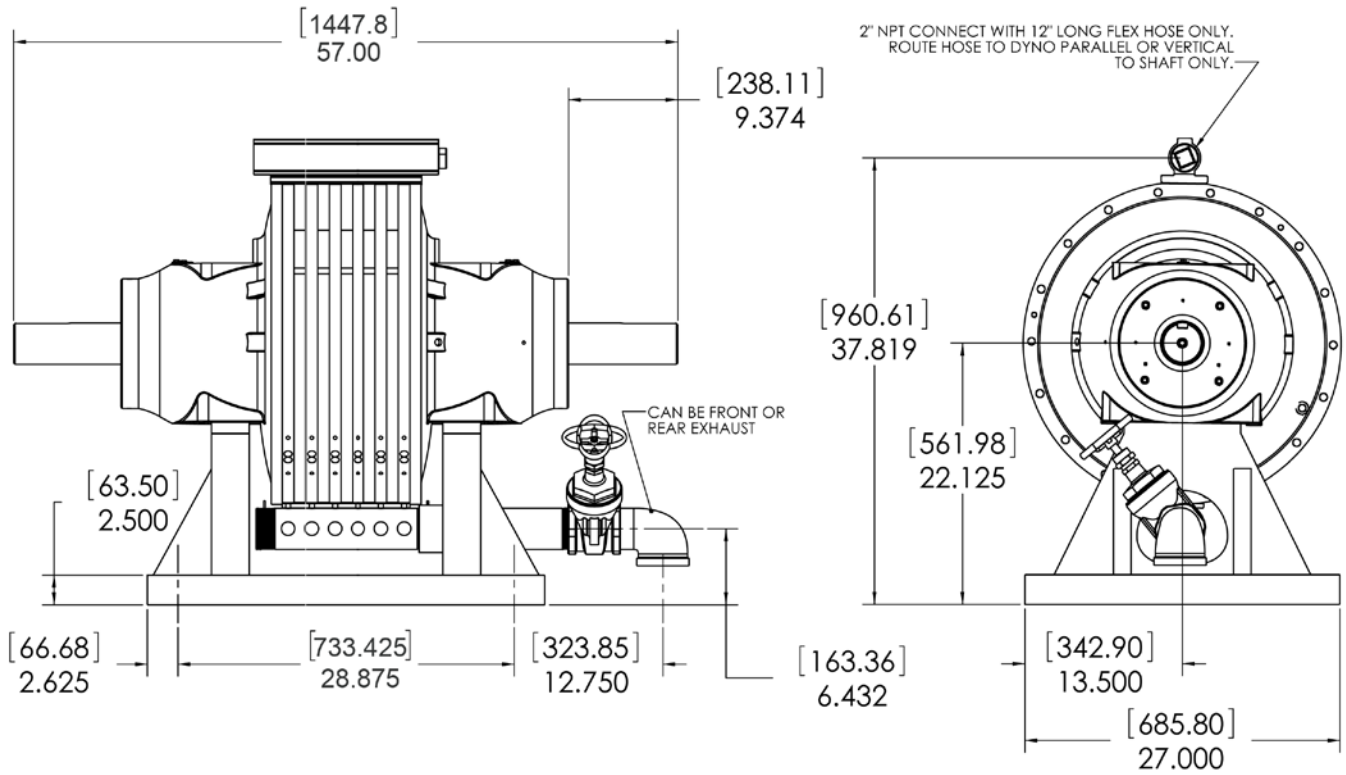

Specifications

Power:	2,125 hp (1,584 kW)
Torque:	7,125 lb-ft (9,660 Nm)
Speed:	4,000 rpm
Water Use*:	147 gpm (556.5 lpm)
Inertia Value**:	172.4 lb-ft ² (7.3 kg·m ²)
Shipping Weight:	2,860 lb (1,297 kg)
Rotation:	bi-directional

*No Cooling System

** With Companion Flange or Torsional Coupling

As a safety precaution, Taylor Dynamometer recommends a torsional analysis to uncover any potential torsional problems that exist for each application. This analysis will identify any torsional issues (frequencies) that should be fixed prior to operation. Excessive linear vibration may also create problems that must be mitigated for continued operation. It is the customer's responsibility to ensure that these vibration issues are addressed upon application of the dynamometer. Equipment failures attributed to linear or torsional vibration are not warrantable.

Everything you need to succeed



3602 West Wheelhouse Road, Milwaukee, Wisconsin 53208 U.S.A.
(414) 755-0040 www.taylordyno.com

SMS2019v005