



# Flywheel Adapter Kit

TD-3100

# Flywheel Adapter Kit

## Save \$\$ by Machining Yourself

The flywheel adapter plate bolts to the flywheel of the engine. The flywheel adapter plate is available with a rough-cut diameter, from 15" to 24" and is pre-formed and machined to mate with a hub. Final machining of the outside diameter and drilling of the attaching holes to fit the clutch cover bolt holes in the flywheel must be performed by the purchaser to ensure correct fit. A single flywheel adapter plate can be drilled with various flywheel patterns, thus avoiding the necessity of stocking a different plate for each model of engine to be tested. The hub is bolted to the flywheel adapter plate to ensure proper location and centering of the dynamometer. A spacer is introduced between the flywheel housing adapter and the trunnion housing to compensate for the adapter plate and 3100 style hub build up. Additional adapter plates are available for purchase separately.

## Items Included with Kit

- One 3100 Style Hub
- Two 15" diameter Adapter Plate Blanks
- Two 18" diameter Adapter Plate Blanks
- One 24" diameter Adapter Plate Blank
- One Adapter Plate Hanger Kit
- One TD3100 Spacer

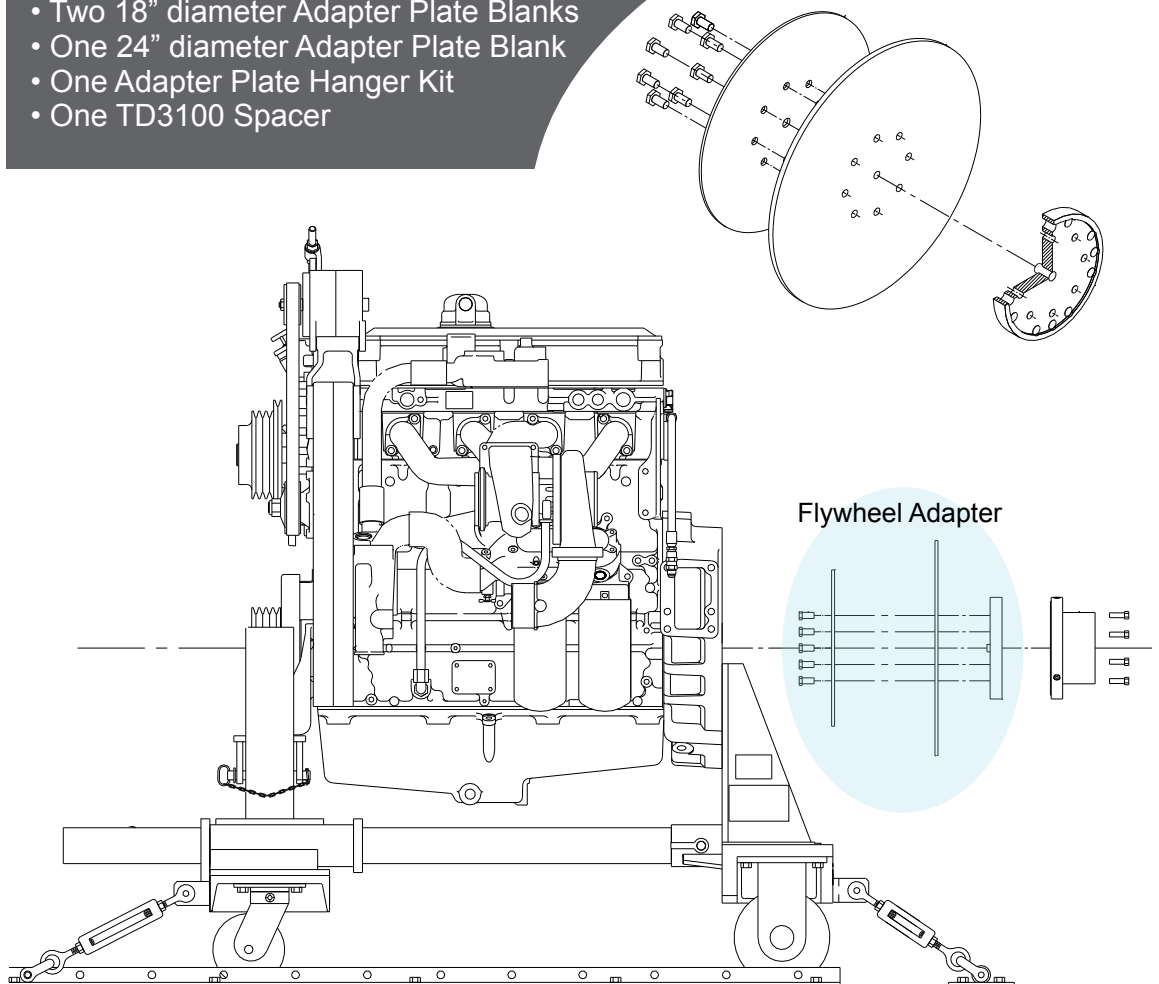

SMS0873V004