



## Engine Dynamometer Exhaust Systems

# Engine Exhaust

### Exhaust Hood for Engine Dynamometer

Taylor Dynamometer can design a Hood style or Closed Exhaust extraction system to meet the unique requirements of your facility. Exhaust extraction systems for engine test cells encompass both engine and general test cell air extraction to ensure both proper engine operation and the safety of your personnel.



Each facility is different and therefore requires that a system be designed to adapt to the individual building requirements. A Hood style Exhaust system is preferred since it does not require any engine connections and thereby reduces the test time and labor involved with setup. If an overhead crane is to be used to move engines into and out of the test cell, the standard Hood style system cannot be used. A custom Hood Style system may be an option for use with an overhead crane however facility layout and other design restrictions may not allow this option. The Hood style exhaust system pulls make-up air into the test cell and removes both engine and room exhaust. In addition, a small rotary ventilator should be installed to permit the escape of any fumes not captured.

### Closed Exhaust System for Engine Dynamometer

A Closed Exhaust System requires direct connection to the engine exhaust system. This style of system allows for the greatest flexibility when overhead and in cell jib cranes are to be used. The Closed Exhaust System removes only engine exhaust. A separate fan-powered exhaust system is required to pull in make-up air and discharge the heat and fumes. Contact your Taylor Dynamometer Sales Representative for system specifications and pricing.



# Engine Exhaust

ITEM	QTY	Part #	Drawing #	REVISION	DESCRIPTION
1	1	C-0102250-08	A10483	001	CANOPY 8X18 ENGINE EXHAUST
2	3	3C-160502	A14339	001	ADAPTER ASST EXHAUST CANOPY ENGINE
3	3	1N22820		000A	FAN EXHAUST 380T/1520HZ/18CFTM

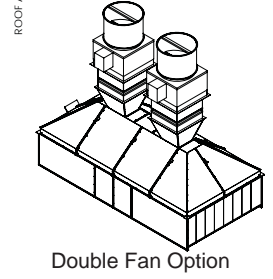
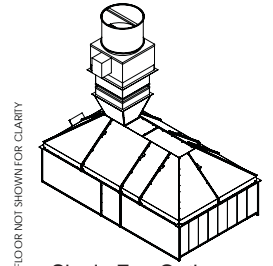
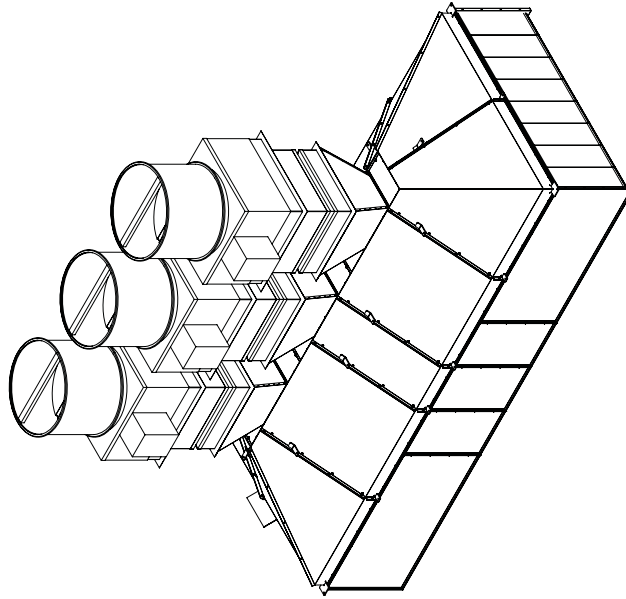

ROOF AND FLOOR NOT SHOWN FOR CLARITY

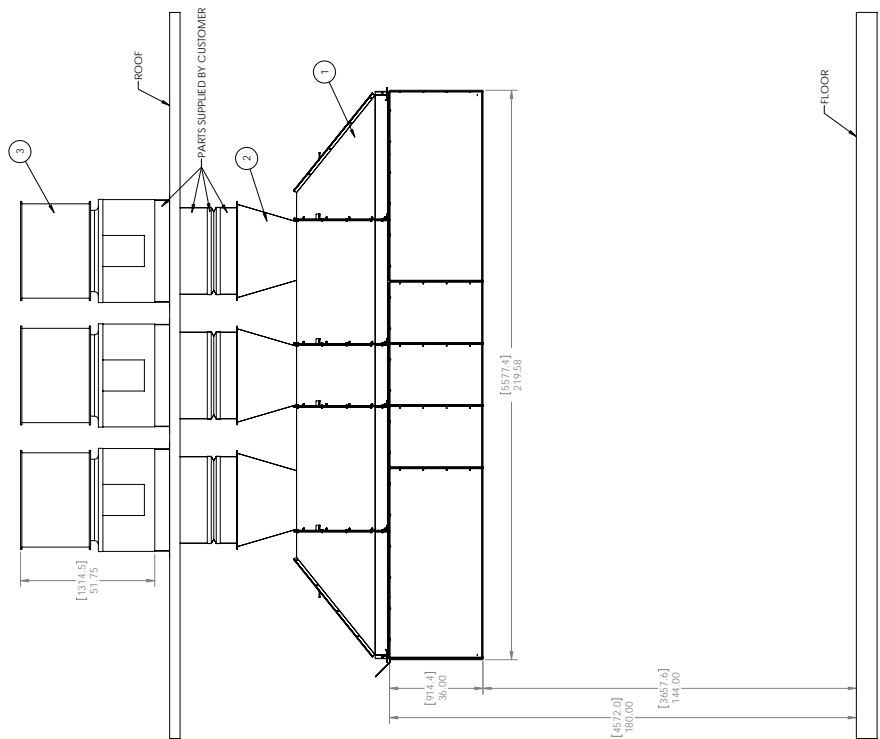
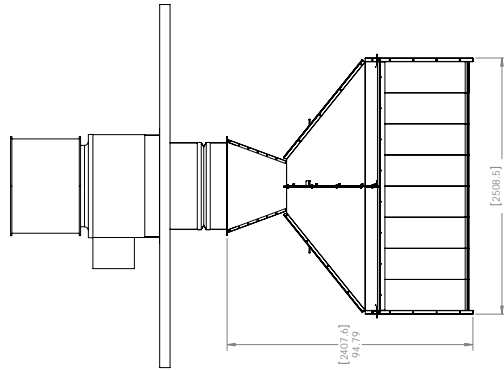

SMS944v003