



Engine Dynamometer

DA900

Engine Dynamometer

Air-Cooled AC Dynamometer



Specifications

Power: 985 hp (735 kw)

Torque: 3,449 ft. lbs (4,676 Nm)

Speed: 3000 RPM

Shipping Weight: 1,320 lbs. (598.74 kg)

Recommended Accessories:

- Base Kit
- Driveshaft
- Shaft Guard
- Cooling Column
- Engine Cart
- Adapter Plate Kit
- DynPro Instrumentation
- Charge Air Cooler
- Load Bank or Regenerative Drive configuration

DA900 (English)

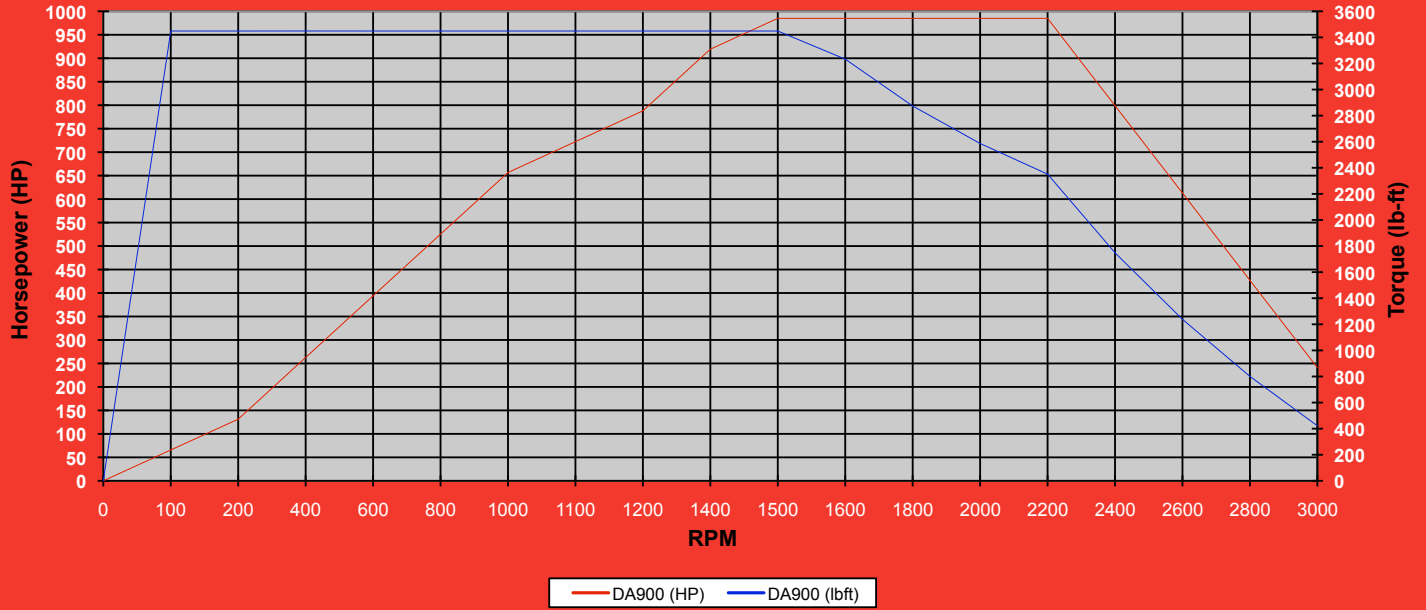

DA900 (Metric)

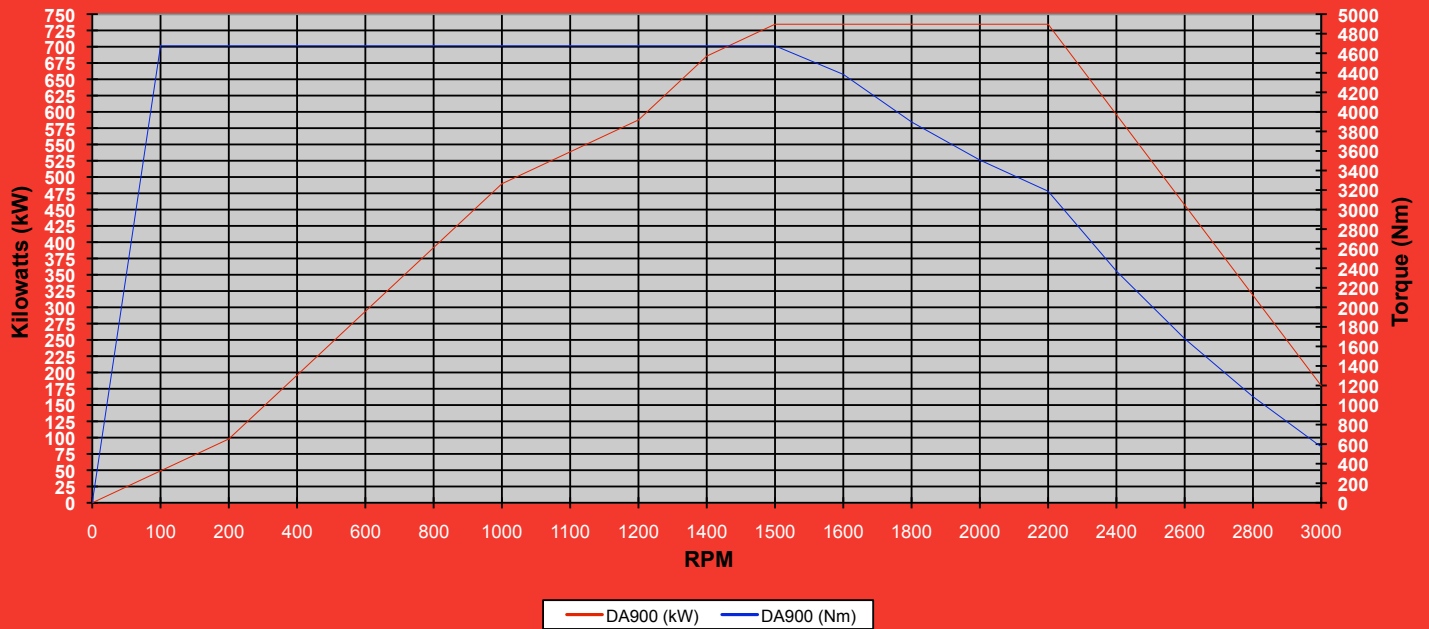

DA9000

Engine Dynamometer

Taylor Dynamometer

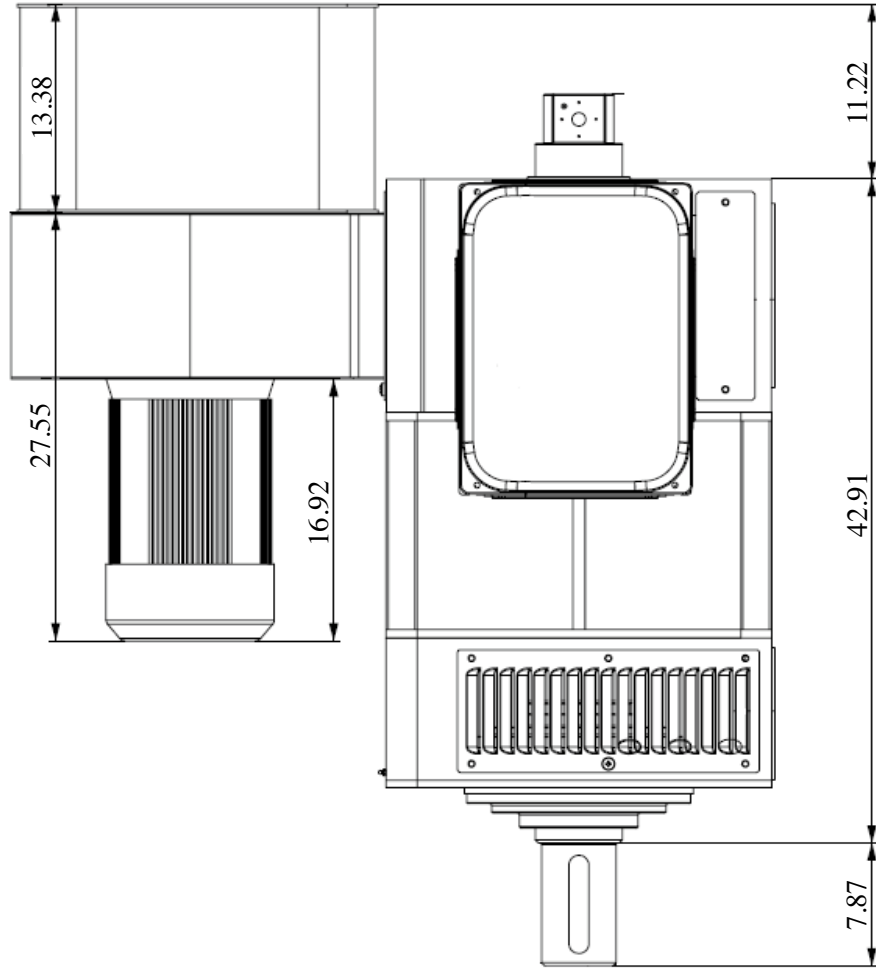
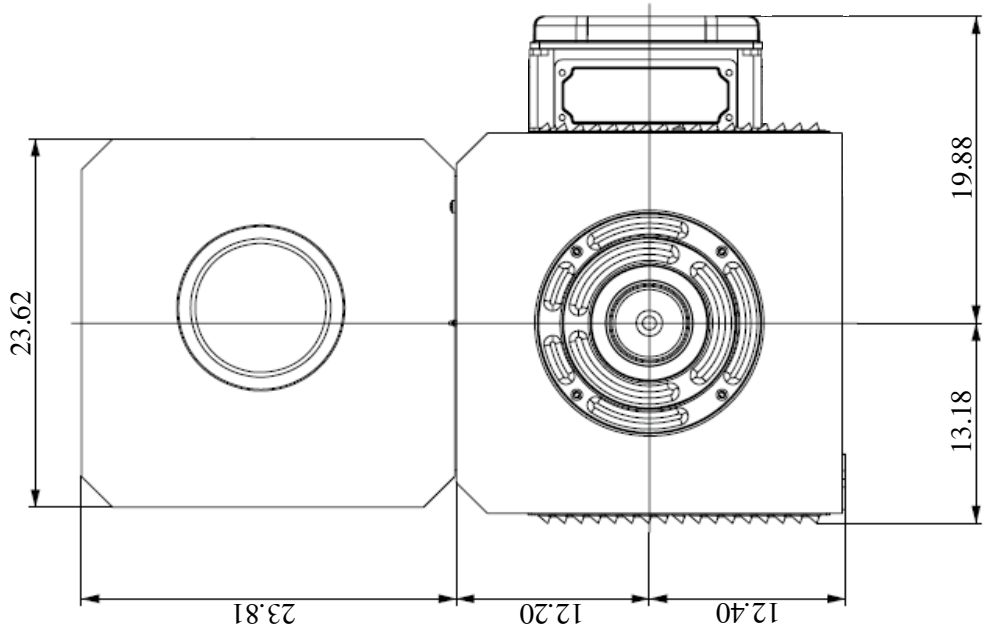

POWER: 985 hp (735 kw)

SPEED: 3000 RPM

TORQUE: 3,449 ft. lbs. (4,676 Nm)

SHIPPING WEIGHT: 1,320 lbs. (598.74 kg)

All measurements in inches.

SMS1112V001

3602 West Wheelhouse Road, Milwaukee Wisconsin U.S.A
www.taylordyno.com 414-755-0040