

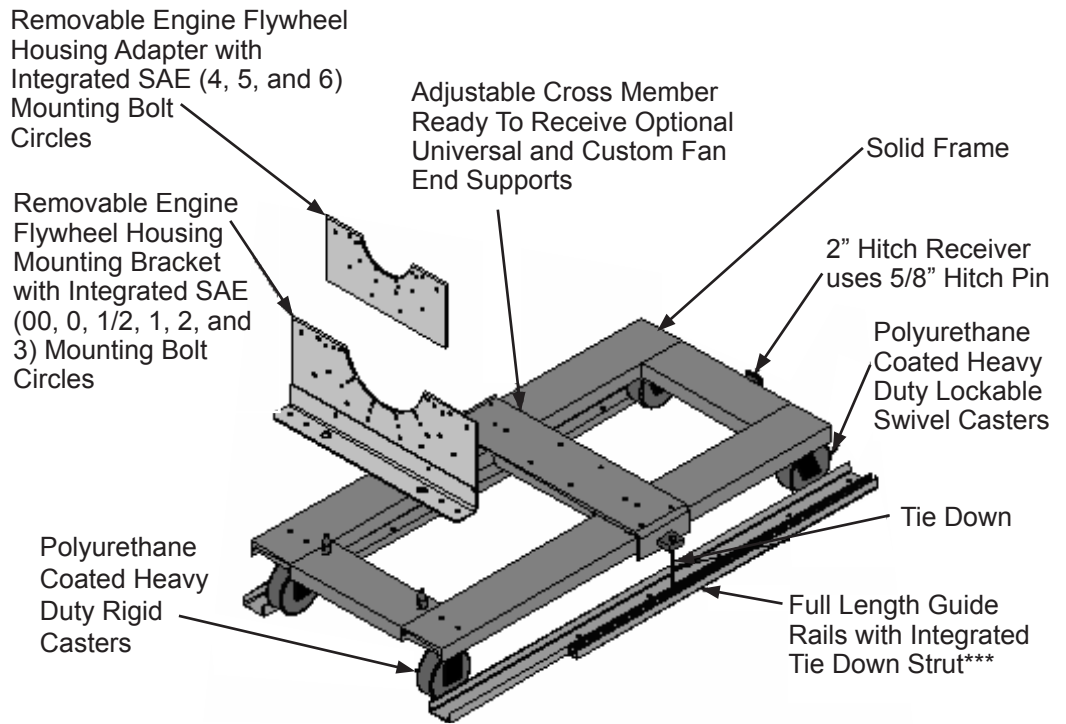

6000 lb. Engine Cart

6000 lb. Engine Cart

Outline & Interface Dimensions of 6000 lb. Engine Transit and Testing Cart



Note:

Dead Weight Capacity 6000 lb. [2721 kg]

*** Mounting Hardware Not Included

1/2" [M12] 3000 lb. [13KN] Pull Out Strength Floor Anchors are Recommended.

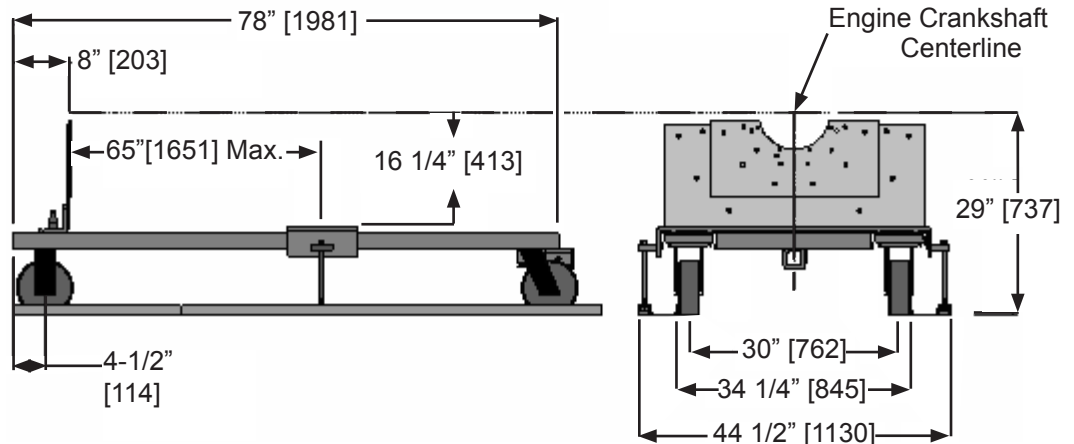

SMS0414v008